

Hybrid Hay Runner Hay Rake

Instruction Manual and Parts List For Hay Rakes after serial #3999

Use this manual for safety instructions and operating instructions.
Make sure that everyone who operates this machine has read this manual completely!
Save for future use.



OGDEN

Metalworks, Inc.
301 N. Marilyn Avenue – PO Box 128
Ogden, IL 61859
217-582-2552 – Fax 217-582-2746
www.ogdenmetalworks.com
11-14R0915

Quick reference guide

Note: The minimum tractor hydraulic system requirement for the *Hybrid* Hay Runner is 1900 psi.

Grease all pivot points

Before using the rake all pivot points should be greased. This includes the cylinder clevis pin, hinges and the rake arms. The zerks for the rake arms are on the bottom side of the I series tubes. When greasing these be sure to move the rake arms up and down several times to insure proper lubrication.

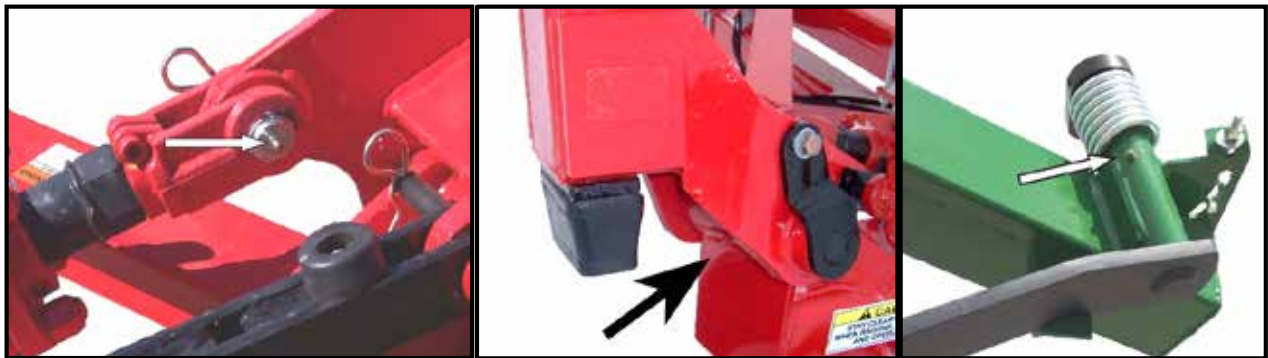

Tongue adjustment

The Hybrid Hay Runner is shipped fully assembled except for the I series rake assemblies and rake wheels. For shipping purposes the tongue is shipped in the shortest position. **“Important”** Before using the rake loosen the u bolts, loosen the hose holder on top of the tongue so the hoses will slide through and lengthen the tongue as necessary to avoid any problems.

Tongue Clevis Adjustment

It is very important that the Hybrid Hay Runner operates level. **“Important”** The tongue clevis is adjustable and should be adjusted so the rake is as level as possible when raking.



Installing the I Series Arms

Attach the I Series Rake Assembly to the pivot arm using 5/8" x 4" x 5" u-bolts, lockwashers and hex nuts. The I Series Rake Assembly should be mounted where indicated on the tube. If the tube is not marked measure 96 1/2" from the rear edge of the tube and mark the tube. All 8 wheel rakes require an adjustment plate be installed when attaching the I series tubes to the pivot arms. This is necessary to insure the I series tubes are as close to level as possible. Install the adjustment plate between the 4" x 4" I series tube and the pivot arm mounting plate. Attach the I series rake to the pivot arm at the mark and check for wheel clearance. It may be necessary to adjust the mounting location slightly to provide proper clearance. Be sure to tighten the u bolts so the 4" x 4" I series tube is as level as possible on all rakes. If an 8 wheel rake is converted to a 10 or 12 wheel rake, then remove the adjustment plates. Adjustment plates are only necessary and supplied for the 8 wheel rakes.

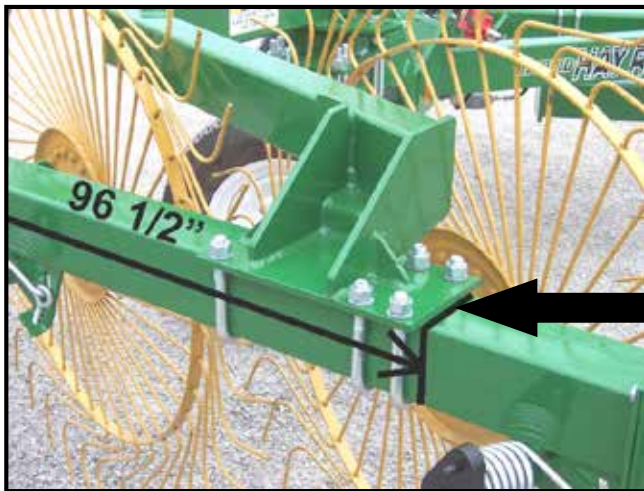

Install adjustment plate for 8 wheel rake here, between tube and pivot arm

Installing Rake Wheels

The Hybrid Hay Runner has right and left hand rake wheels and it is important that they are installed correctly. The rake tines at the bottom of the wheel where the tine touches the ground should point forward. The carriage bolt heads in the center of the wheel should be on the side of the wheel that touches the hay. See picture below.

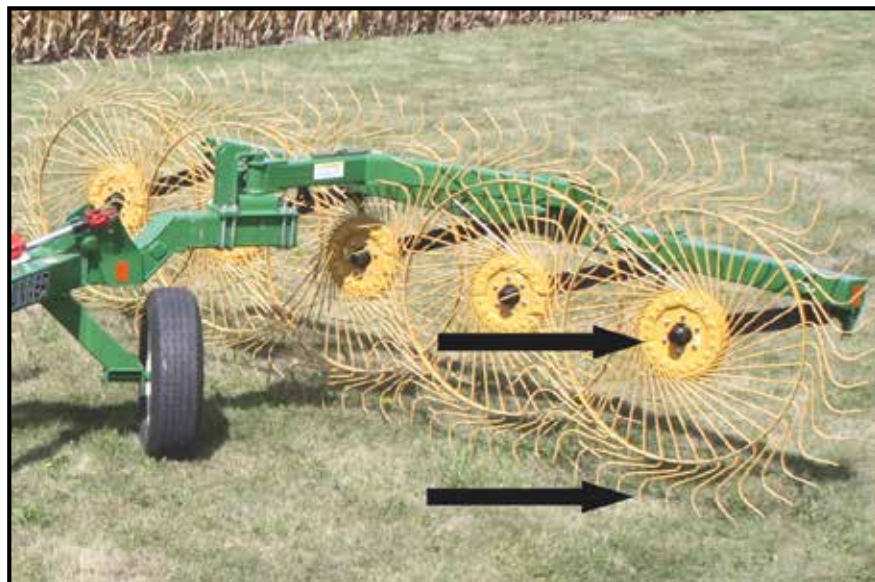

Wing adjustment

The Hybrid Hay Runner is normally shipped with the wings adjusted inward. Loosen the u bolts and move the rake assemblies outward to achieve a wider raking width and windrow. The rear 2 rake wheels can be independently adjusted without affecting the overall raking width. This allows operating the rake at a steeper angle in heavy crops and maintaining a narrower windrow or operating the rake at a flatter angle in light crops and maintaining a wider windrow.

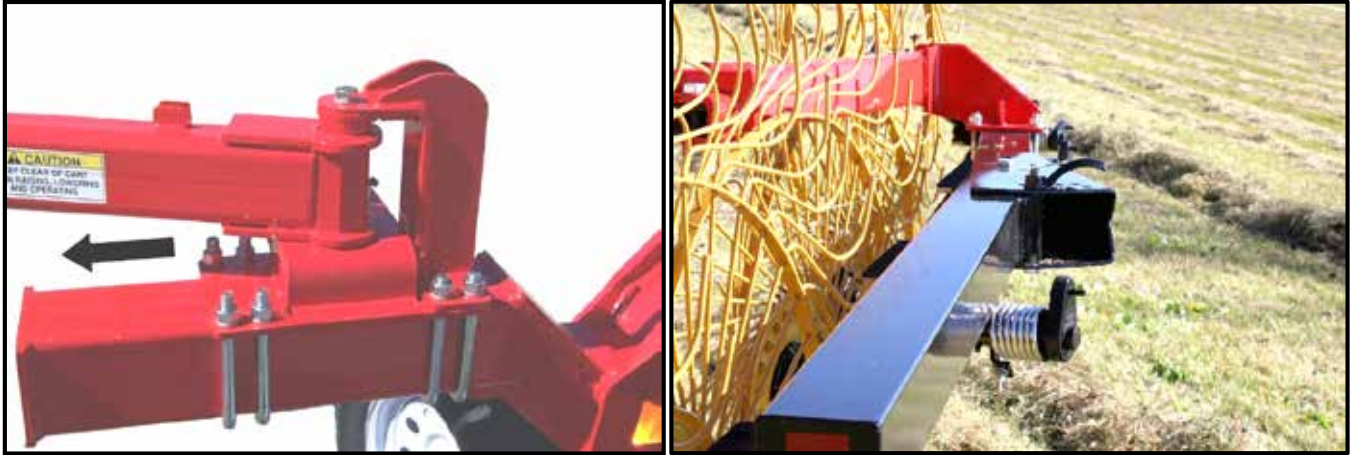

Front Wheel Adjustment

The front rake wheel on the HR10 can be lifted and held up during operating in order to reduce the overall raking width. The front 1 or 2 rake wheels on the HR12 can be lifted as well. This is done by removing the keeper pin and clip. Raise the wheel, turn the clip over and install over the arm. Replace the keeper pin.

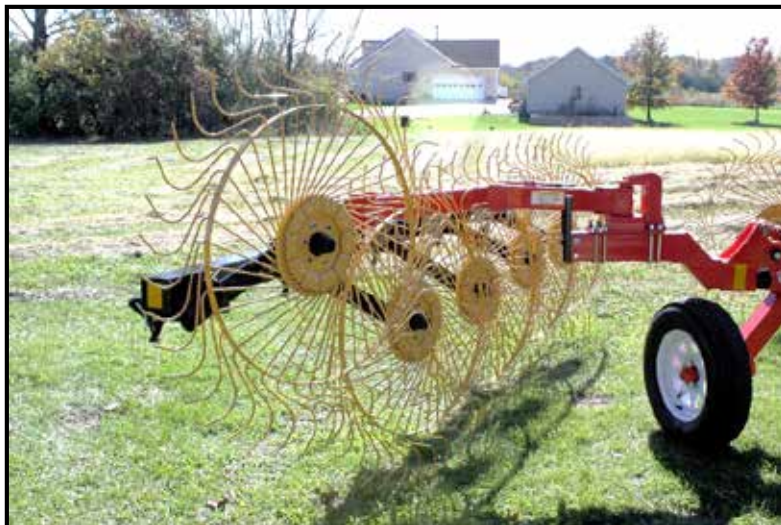

Rake angle adjustment

The rake angle is adjusted by loosening the locknut on the ratchet jack, inserting the handle into the ratchet jack and pivoting the rake assembly. When the desired angle is achieved be sure to retighten the locknut and secure the handle in the holder.



Adjusting Rake Wheel ground pressure

Rake Wheel ground pressure can be controlled by adjusting the torsion spring on each wheel. Tighten the nut on the eye bolt to decrease the ground pressure and loosen the nut to increase the ground pressure.



The rake wheels are ground driven and require good ground contact in order to operate properly. Adjust the wheel ground pressure to achieve good raking action without damaging the crop. Do not exceed the amount of rake wheel ground pressure necessary. Excessive rake wheel ground pressure can cause crop damage and premature rake wheel tooth wear.

Table of Contents

Table of contents	1
Introduction	2
Safety Instructions	3
Decals	4
Assembly	5
Hydraulic System	8
Center Wheel Kit	8
Operation	9
Ground Pressure Adjustment	10
Operating with one rake	11
Transporting	11
Maintenance	12
Lubrication	12
Main Frame Parts List	14
Axle and Wheel Assemblies	15
Rake Arm & Rake Wheel Parts List	18
Hydraulic System Parts List	20
Single Center Wheel Kit Parts List	22
Single Center Wheel Kit Installation	24
2 WH Center Wheel Kit Parts List	28
2 Wheel Center Wheel Kit Installation	30
Warranty Policy & Warranty Card	33

Introduction

The *Hybrid* Hay Runner Hay Rake has been engineered and built for ease of operation and long service life. This Operator's Manual will provide important safety and operational information. It is important that you thoroughly understand the operation of the *Hybrid* Hay Runner Hay Rake before use. Failure to follow the instructions in this manual may result in personal injury and or damaged equipment and could void the warranty. Please do not assume you know how to operate and maintain this machine before you have completely read this manual. Store this manual in the Manual Canister on the tongue for future reference.

Read through this manual completely, watching especially for safety symbols (see illustration below) which will alert you to possible safety hazards. This safety alert symbol is used throughout this manual to identify possible safety hazards.



The word "*Note*" will alert you to special information such as specifications, techniques, reference information and other supplementary information. It is the user's responsibility to read the operator's manual and comply with all the instructions pertaining to operation and maintenance. It is also the user's responsibility to inspect the machine at regular intervals and repair or replace worn or damaged parts when continued use would cause damage or excessive wear to other parts. The word "*Important*" is used to point out a note which is of an immediate and urgent nature.

The manufacturer reserves the right to make improvements, discontinue or change specifications, models or design without notice and without incurring obligation.

When ordering parts, for your *Hybrid* Hay Runner Hay Rake, please specify the part number and the part description as shown in the parts listing in this manual. Please give the serial number of the *Hybrid* Hay Runner Hay Rake in all correspondence when referring to the Hay Rake. Please record the following information here for future use.

Serial Number _____

Model _____ **Purchase date** _____

Dealer _____

Address _____

Phone number _____

IMPORTANT: When this machine is traded or sold, make sure this manual accompanies the machine so future operators will have complete operating instructions and safety warnings available to them.

Safety Instructions



CAUTION: This machine should never be operated by anyone who is not familiar with the product and has not read the instruction manual. Do not allow children to operate the Hay Rake.

All persons operating this machine should read and understand the Instruction Manual.

Read and understand all safety decals located on the machine.

Keep Safety Decals clean and legible at all times.

Replace Safety Decals that are missing or become illegible.

Do not allow anyone to ride on the machine.

Be sure machine is attached securely to the tractor before operating or transporting.

Inspect the *Hybrid* Hay Runner daily. Lubricate and repair or replace parts as needed.

Maintain and keep all Safety Shields in place.

Make sure the Wings are locked whenever they are in the folded position before working around the machine or for transporting.

Before operating the machine inspect for loose or damaged bolts or parts and make necessary repairs before starting.

All bystanders should be a safe distance from the machine when in operation.

High-pressure oil leaks can penetrate skin causing serious injury. Do not use your finger or other skin to check for leaks.

Apply parking brake and stop tractor engine before dismounting tractor.

Keep hands, feet and clothing away from moving parts.

Never transport faster than surface conditions allow.

Display the SMV Emblem when transporting with a tractor.

Make sure you are in compliance with all local regulations regarding transporting agriculture equipment on public roads and highways. Consult your local law enforcement agency for further details.

Ensure that the Slow Moving Emblem (SMV) and all reflectors and lights required by the local highway and transport authorities are in place and are clean and visible by overtaking and oncoming traffic.

Decals

Important: The following decals or similar decals are located on your *Hybrid* Hay Runner Hay Rake. Before you operate the *Hybrid* Hay Runner Hay Rake, read and understand the purpose for each decal. Replace any damaged decals. Keep all decals clear and readable.

1.



2.



3.



4.



5.

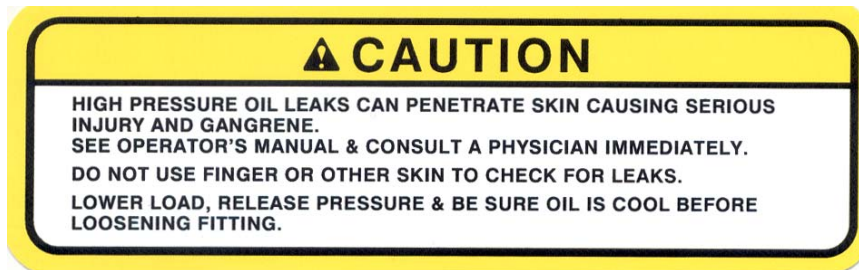

6.

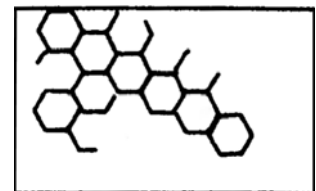

7.

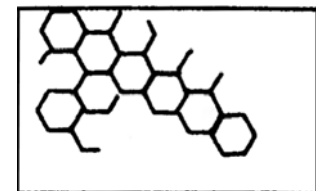

Decal Parts List

Item No.	Part No.	Description	Qty.
1	HR169	Decal, Warning Operating	1
2	HR170	Decal, Overhead Hazard	2
3	0-70	Decal, Caution Stay Clear	5
4	HR171	Decal, Warning Pinch Point	2
5	0-82	Decal, Hydraulic Caution	1
6	0-71	Decal, Red Reflector	2
7	B489A	Decal, Yellow Reflector	2

ASSEMBLY INSTRUCTIONS

CAUTION! Wear proper protective equipment such as safety glasses and protective shoes when assembling.



Use the following assembly instructions if you received the *Hybrid* Hay Runner Hay Rake partially or completely unassembled. The assembly area should be a clean flat solid surface. It may be necessary to use lifting mechanisms and sturdy supports.

1. Lay out and identify all parts. Many parts will be partially assembled.
2. Support the main frame on sturdy stands. Install the tongue on the main frame using four 5/8" x 5"x 7" u-bolts, lockwashers and hex nuts. The length of the tongue is adjustable and should be set according to the size of the rakes being used.



3. Install the axle struts to the rear of the main frame using 5/8" x 2" hex capscrews, lockwashers and hex nuts. Attach the SMV bracket to the LH wheel strut bolts as shown in the picture below. Mount tires and rims to hubs using lug bolts. Torque lug bolts to 75 ft-lbs.



6

4. Install the threaded rod hose holder through the manual canister and into the threaded hole on the top of the tongue. Install a 1/2" jam nut on the rod before installing. Tighten the hex jam nut after the rod is positioned. Attach the other end of the manual canister to the tongue using a 3/8"x 1" hex capscrew and lockwasher.



5. Install the tongue support jack on the tongue using the pin supplied.

6. Attach tongue clevis to the tongue using two 5/8" x 7" hex capscrews and nylock hex nuts. The height of the clevis can be adjusted to match the drawbar height of the tractor. The Hay Rake should always be level for proper operation.

7. Mount the right hand and left hand wing arms to the main frame using the hinge pins. Clean and lubricate the hinge pins before installing. After installing attach the stop washer, 3/4" lockwasher and 3/4" x 1 1/4" hex capscrew and secure the pin in place using 1/2" SAE flatwasher, 1/2" lockwasher and 1/2" x 1 1/4" hex capscrew.



8. Attach the pivot arm adaptors to the wing arms using just the two outside 5/8" x 5" x 7" u-bolts, lockwashers and hex nuts. The location of the adaptors on the wing varies depending on windrow width desired. Normally they will be as far out on the wing as possible.

9. Mount the pivot arms onto the pivot arm adaptors. Clean and lubricate the shaft on the pivot arm adaptor before mounting pivot arm.

10. Attach the pivot support to the pivot plate and pivot arm using two 5/8" x 5" x 6 5/8" u-bolts, lockwashers and hex nuts and one 3/4" x 1 3/4" grade 8 hex capscrew and lockwasher.

- 11.** Attach the ratchet jacks to the pivot adjustment plates and pivot arms using 1" x 5" capscrews and nylock nuts.



- 12.** Attach the I series Rake Assembly to the pivot arm using 5/8" x 4" x 5" u-bolts, lockwashers and hex nuts. The I series rake assembly should be mounted where indicated on the tube. If the tube is not marked measure 96 1/2" from the rear edge of the tube and mark the tube. All 8 wheel rakes require an adjustment plate be installed when attaching the I series tubes to the pivot arms. This is necessary to insure that the I series tubes are as close to level as possible. Install the adjustment plate between the 4" x 4" I series tube and the pivot arm mounting plate. Attach the I series rake to the pivot arm at the mark and check for wheel clearance. It may be necessary to adjust the mounting location slightly to provide proper clearance. Be sure to tighten the u bolts so the 4" x 4" I series tube is as level as possible on all rakes. If an 8 wheel rake is converted to a 10 or 12 wheel rake, then remove the adjustment plates. Adjustment plates are only necessary and supplied for 8 wheel rakes.

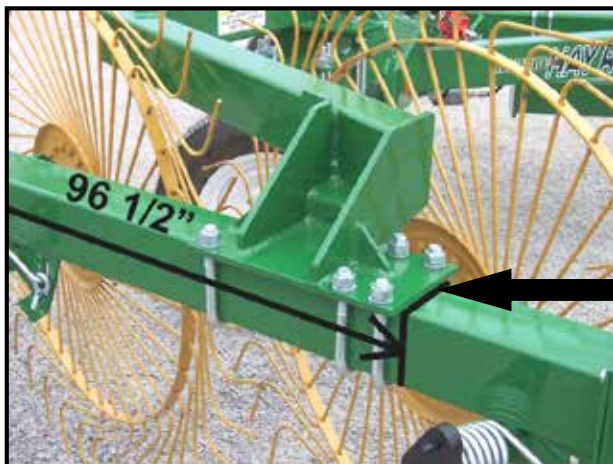

Install adjustment plate for 8 wheel rake here, between tube and pivot arm.

- 13.** Mount all of the rake wheels to the rake wheel hubs using 3/8" whiz nuts. Standing behind the rake and looking forward the rake wheels marked RH go on the right side and the rake wheels marked LH go on the left side with the smooth carriage bolt heads towards the hay and the rake tooth at the bottom of the wheel pointing forward.

- 14.** Attach the transport locks, with the rubber bumper on the bottom, to the main frame using a 5/8" x 2 1/2" hex capscrew and nylock hex nut.

Hydraulic System

Note: The tractor hydraulic requirement for the Hay Runner is 1900 psi.

The Hydraulic System will be factory installed. Keep hoses and fittings clean at all times. Be sure all connections are properly sealed to avoid leakage. **Note:** Do not use Teflon thread tape. Only use a liquid type thread sealant.

CAUTION!



Operate the hydraulic cylinders through the cycle a few times to expel all air from the system. Failure to fully charge the hydraulic system could result in injury when the rakes fall abruptly to the ground.

CAUTION!



Always wear protective eye goggles and use a magnifying glass or hold a piece of wood on suspected leaks. Pinhole hydraulic leaks can penetrate skin. Do not touch.

Note: If fluid penetrates the skin, it must be surgically removed within a few hours by a doctor familiar with the form of injury or gangrene may result. Make sure the weight of the machine has been taken off the hydraulic cylinder before disconnecting hydraulic hoses.

Center Wheel Kits

Single Wheel and 2 Wheel Center Wheel Kits are available. The Single Wheel Kit is shown in the pictures below. The Center Wheel Kit mounts on the back of the *Hybrid* Hay Runner and is designed to move the hay that lays in the center and does not get touched by the main rake assemblies. Opening the hydraulic valve on the cylinder and removing the safety pin allows the center wheel to raise and lower with the rakes. When transporting, the center wheel kit can be locked by closing the hydraulic valve and by using the locking pin. Be sure to remove the locking pin before applying pressure to the hydraulic cylinder or damage may occur.



Operation

Before operation, check tightness of lug bolts, spindle set screws and grease all pivot points and cylinder clevis pins.

Important: Before operation, the operator should be familiar with these operation instructions and operation of the tractor. Do not allow an unqualified person or one under the influence of medication or intoxicating substances to operate the tractor.

1. It is very important that the **Hybrid** Hay Runner is level in the operating position. In order to level the implement, remove the bolts and adjust the clevis up or down so that the rake is level. Connect the machine to the tractor tongue using a 3/4" hitch pin with retaining clip. The adjustable jack will allow the tongue to be raised or lowered during hookup. After hookup to the tractor, be sure to store the jack by mounting it on the extra mount provided towards the back of the tongue.

2. Connect the hydraulic inlet and outlet hoses to the tractor system.

CAUTION!



Do not exceed manufacturers' maximum hydraulic system pressure 3000 psi.

3. To lower the rakes to the working position, turn off tractor and remove key. Remove the transport lock pins for each wing and rotate the transport locks out of the way. Store the transport lock pins back in the transport lock. Rotate the shut off valves to the open position or inline with the hoses. Apply hydraulic pressure to the cylinders and lower the wings to the ground.

CAUTION!



Make sure the area around the machine is clear before lowering. Do not lower machine when people or pets are near the machine or folding mechanism.

4. The overall rake working width is adjusted by loosening the 5/8" u-bolts and sliding the rake arm assembly in or out to the desired windrow width. Be sure to retighten u-bolts. The rear 2 wheels on the I series tubes can be adjusted to narrow or widen the windrow without affecting the overall raking width. Remove the locking pin and adjust the 2 wheel section in or out to obtain the desired windrow width. Replace the pin and tighten the locking handle. This allows operating the rake at a steeper angle in heavy crops and maintaining a narrower windrow or operating the rake at a flatter angle in light crops and maintaining a wider windrow.



Front Rake Wheel Adjustment – The front rake wheel on the HR10 can be lifted and held up during operating in order to reduce the overall raking width. The front 1 or 2 rake wheels on the HR12 can be lifted as well. This is done by removing the keeper pin and clip. Raise the wheel, turn the clip over and install over the arm. Replace the keeper pin.

10

5. The rake angle is adjusted by loosening the locknut on the ratchet jack, inserting the handle into the ratchet jack and pivoting the rake assembly. When the desired angle is achieved be sure to retighten the locknut and secure the handle in the holder.



6. Begin raking at a low ground speed until you are familiar and comfortable with the rake. Working speed is normally 5 to 10 mph. Ground speed will vary with different hay conditions or terrain.

7. To raise the rakes, apply hydraulic pressure to the hydraulic cylinders. When the wings are in the fully raised position, install the transport locks and pins and close the hydraulic lock valve to each wing.

Adjusting Rake Wheel ground pressure

Rake Wheel ground pressure can be controlled by adjusting the torsion spring on each wheel. Tighten the nut on the eye bolt to decrease the ground pressure and loosen the nut to increase the ground pressure.



The rake wheels are ground driven and require good ground contact in order to operate properly. Adjust the wheel ground pressure to achieve good raking action without damaging the crop. Do not exceed the amount of rake wheel ground pressure necessary. Excessive rake wheel ground pressure can cause crop damage and premature rake wheel teeth wear.

CAUTION!

Before doing any maintenance, adjustments or repairs on the machine, shut off the tractor engine, remove the ignition key and wait until all moving parts stop.

Operating with one rake

In order to operate with just one rake down, it is necessary to remove the transport lock and pin and open the hydraulic transport lock valve, located at the hydraulic cylinder, for the rake that you want to use. The open position is when the valve handle is in line with the valve body. Be sure the transport lock and pin are in place on the rake that you do not want to lower and that the hydraulic transport lock valve located at the hydraulic cylinder is closed. It is necessary to open the hydraulic bypass valve when raking with just one rake. The open position is when the handle is in line with the valve body. Be sure to close the bypass valve when using both rakes. Refer to decal on frame above Bypass valve for proper setting.

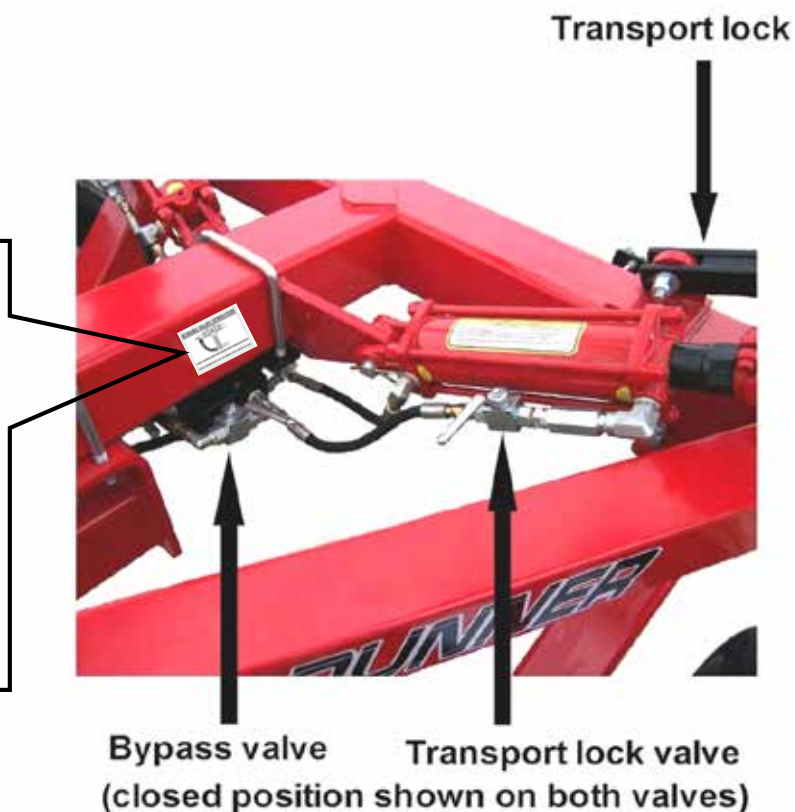
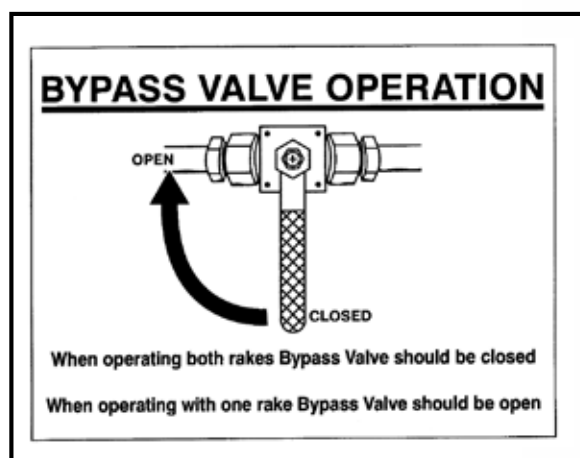
**CAUTION!**

Before lowering the rake make sure all bystanders are a safe distance out of the way. Allow ample clearance around the implement when raising or lowering the rakes.

12

Transporting

CAUTION!



Never transport rakes without the hydraulic valves closed and Transport Locks and locking pins in place.

Make sure the rakes are in the raised transport position. Close the hydraulic transport lock valves and make sure the transport locks and pins are in place locking the rakes. Avoid sharp turns during transport. Slow down when approaching trees, fences or ditches to avoid damage to the rakes. Transport at tractor speed.

When transporting the Hay Runner, install an SMV sign in the bracket mounted on the rear of the rake.



CAUTION!



When towing on public roads, a slow moving vehicle (SMV) sign must be installed on the rake so it is visible to vehicles following. Comply with state and local safety requirements at all times.

MAINTENANCE

1. Check periodically and replace any damaged or missing safety decals.
2. Check hydraulic hoses periodically for cracks, abrasions or leaks. Replace defective hoses immediately. Replace worn or broken hoses and fittings with factory replacement parts only.
Note: Do not use Teflon tread tape. Only use liquid type thread sealant.
3. To extend the life of the cylinder and hoses, store the machine under cover. If cover is not available, lubricate exposed cylinder rods with grease or remove the cylinder and hoses and store under cover.
4. Check tightness of lug bolts, spindle setscrews and rake wheel nuts after one hour of operation and every six months thereafter.
5. Replace any missing or broken parts.
6. Check tire pressure whenever maintenance is performed.

7. Check tightness of all bolts periodically.
8. Repack transport wheel bearings at the beginning of each season or after every 50 hours of use.

Lubrication

1. Grease the cylinder pins on the ram end of the hydraulic cylinders after every 20 hours of use. (See picture below)
2. The *Hybrid* Hay Runner has Teflon coated bearings at the main hinge point and rake wheel arm pivot shafts and does not require much lubrication. Grease these points after every 50 hours of use. (See pictures below)

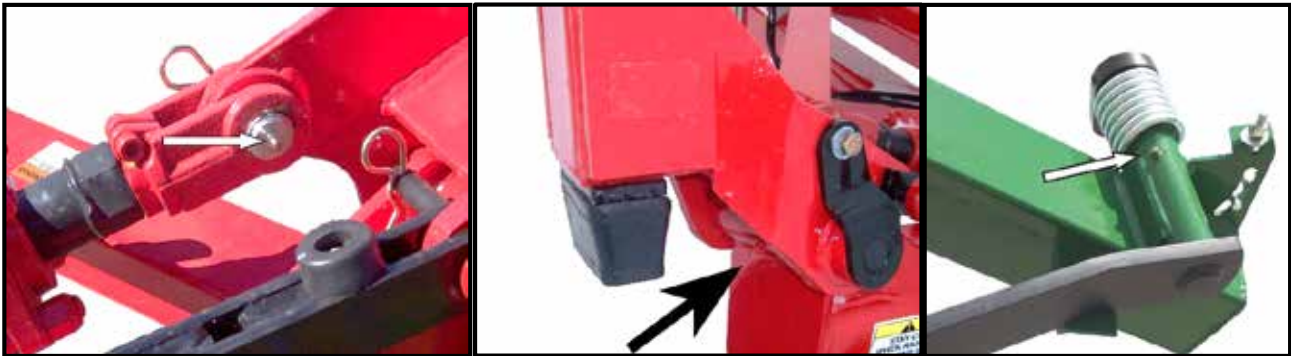

3. The rake wheel hubs have grease zerks and should be greased after every 50 hours of use.
4. Repack transport wheel hubs at the beginning of each season and repack after every 50 hours of use.
5. Tandem Axles should be greased after every 50 hours of use. (See picture below)

Tandem Axles (Optional)

Tandem Axles are optional and can be installed on any *Hybrid* Hay Runner. The wheels on Tandem Axles can be installed inline or offset unless a Center Wheel Kit is being used. The wheels must be inline to avoid interference with the Center Wheel.



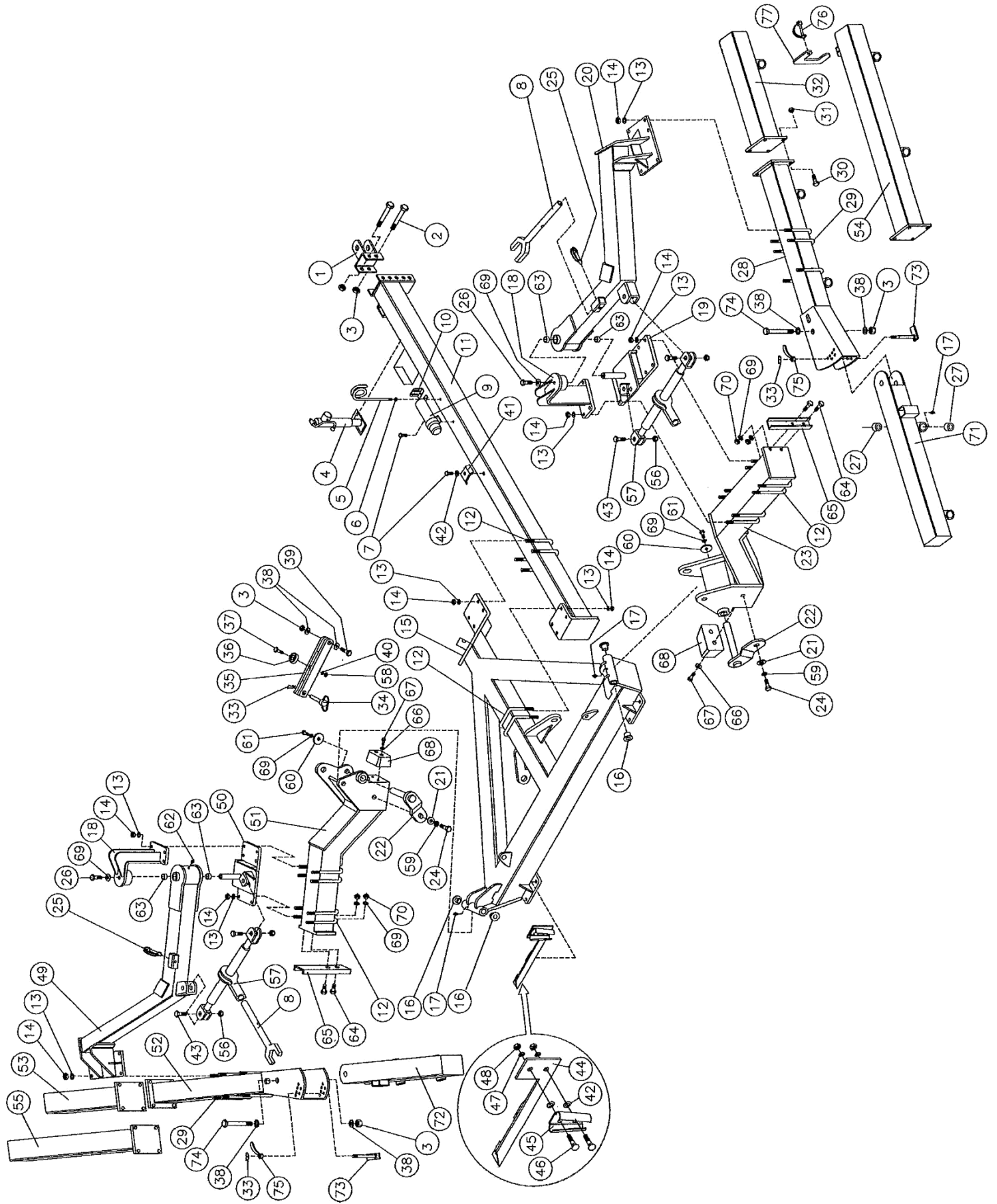

Hay Runner Parts List

Item No.	Part No.	Description	Qty.
1	HR100	Clevis	1
2	HRH587	Hex Capscrew, 5/8" x 7"	2
3	HRH580	Nylock Nut, 5/8"	6
4	0-51	Jack	1
5	0-53	Hose Holder	1
6	0-159	Hex Nut, 3/8"	1
7	K-326	Hex Capscrew, 3/8" x 1"	2
8	HR159	Ratchet Handle	2
9	MH	Operator Manual Holder	1
10	HCTH	Tip Holder	1
11	HR101	Tongue	1
12	UB587	U Bolt, 5/8"x 5 1/16"x 6 5/8"	12
13	OE-155	Lockwasher, 5/8"	36
14	OE-154	Hex Nut, 5/8"	36
15	HR202	Main Frame Weldment	1
16	HRBF175-150	Flange Bushing, 1 3/4" x 1 1/2"	4
17	VM-605-90	Grease Zerk, 1/4" 90°	As req.
18	HR203	Pivot Support	2
19	HR207	Pivot Plate, RH	1
20	HR163	Pivot Arm, RH	1
21	HRSFW12	SAE Flatwasher, 1/2"	2
22	HR204	Hinge Pin	2
23	HR205	Wing Weldment, RH	1
24	HRH12125-8	Hex Capscrew, 1/2" x 1 1/4" GR8	2
25	P7938	Wire Lock Pin, 1/4"	2
26	HRH34150-8	Hex Capscrew, 3/4" x 1 1/2" GR8	2
27	HRB125	Bushing	As req.
28	HR215	4 WH I Series Front, RH	1
29	0-67	U Bolt, 5/8" x 4" x 5 1/4"	6
30	HRH12150-8	Hex Capscrew, 1/2" x 1 1/2" GR8	8
31	0-161	Nylock Nut, 1/2"	8
32	HR219	Single Rake Arm Extension, RH	As req.
33	0-56	Hairpin Clip, 2 15/16" x 5/32"	2
34	HR108	Transport Lock Pin	2
35	HR209	Transport Lock	2
36	791RWS	Small Rubber Bumper, Short	4
37	HRH1425	Hex Capscrew, 1/4" x 2 1/2"	2
38	HRH58SF	SAE Flatwasher, 5/8"	2
39	HRH583-2	Hex Capscrew, 5/8" x 3" GR2	2

Item No.	Part No.	Description	Qty.
40	FW14	Flatwasher, 1/4"	2
41	HR192	Hose Holder	1
42	MCH38F	Flatwasher, 3/8"	4
43	HRH150	Hex Capscrew, 1" x 5"	4
44	HR112	SMV Bracket	1
45	MC117	SMV Mounting Socket	1
46	MCH51615CB	Carriage Bolt, 5/16" x 1 1/2"	2
47	0-176	Lockwasher, 5/16"	2
48	0-177	Hex Nut, 5/16"	2
49	HR164	Pivot Arm, LH	1
50	HR208	Pivot Plate, LH	1
51	HR206	Wing Weldment, LH	1
52	HR217	4 WH I Series Front, LH	1
53	HR220	Single Rake Arm Extension, LH	As req.
54	HR221	2 WH Rake Arm Extension, RH	As req.
55	HR222	2 WH Rake Arm Extension, LH	As req.
56	HRH10N	Nylock Nut, 1"	4
57	HR160	Ratchet Jack	2
58	HRH140	Nylock Nut, 1/4"	2
59	0-173	Lockwasher, 1/2"	2
60	HR210	Washer	2
61	HRH34125	Capscrew, 3/4" x 1 1/4"	2
62	HR201	Zerk, 1/4" 90°	2
63	HRB175-150	Bushing, 1 3/4" x 1 1/2"	4
64	HRH342	Capscrew, 3/4" x 2"	4
65	HR211	Bracket	2
66	HRH58SF	Flatwasher, 5/8" SAE	4
67	HRH5825	Capscrew, 5/8" x 2 1/2"	4
68	HR212	Rubber Bumper	2
69	HRH34LW	Lockwasher, 3/4"	8
70	HRH34N	Nut, 3/4"	4
71	HR216	4 WH I Series Rear, RH	1
72	HR218	4 WH I Series Rear, LH	1
73	HR223	Pin	As req.
74	HRH586	Hex Capscrew, 5/8" x 6"	As req.
75	HR225	Handle	As req.
76	21992	Wirelock Pin, 3/8"	As req.
77	HR224	Clip, Front Wheel	As req.

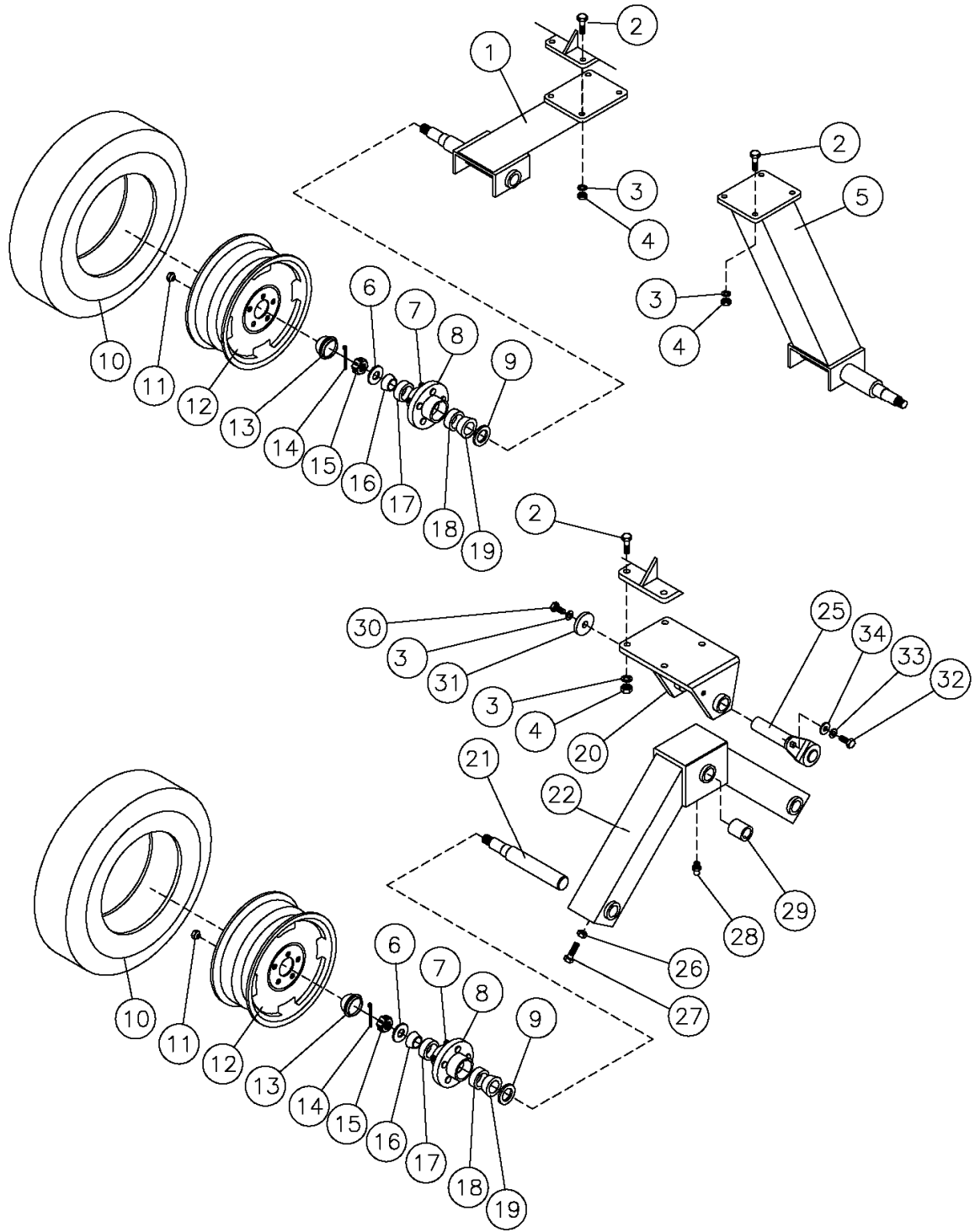

Axle and Wheel Assemblies

Item No.	Part No.	Description
1	HR180	Wheel Strut
2	0-156	Hex Capscrew, 5/8" x 2"
3	OE-155	Lockwasher, 5/8"
4	OE-154	Hex Nut, 5/8"
5	HR180	Wheel Strut
6	951801	Washer, 1.75" OD x 1.125" ID
7	953002	Stud, 1/2"-20 x 1 7/8"
8	280080	Hub with cups
	280090	Hub Complete
9	906281	Seal, CR17146
10	HR117	Rubber Tire, 205/75-15"
11	912919	Lug Nut, 1/2"-20
12	HR133	Rim, 5-15"
13	909900	Hub Cap
14	905936	Cotter Pin, .15" x 1.50"
15	953005	Castle Nut, 1"-14
16	910253	Outside Bearing, L44649
17	910250	Outside Race, L44610
18	910251	Inside Cup, L68111
19	910252	Inside Bearing, L68149
20	HR166	Mounting Bracket
21	286929L14	Spindle
22	HR167	Tandem Weldment
23	HRH516275-8	Hex Capscrew, 5/16" x 2 3/4" GR8
24	HRH516N	Nylock Hex Nut, 5/16"
25	HR194	Pivot Shaft, Tandem
26	0-179	Jam Nut, 1/2"
27	0-178	Setscrew, 1/2" x 1 1/4"
28	VM-605	Grease Zerk, 1/4"
29	HRB175-150	Bushing
30	HRH58125	Capscrew, 5/8" x 1 1/4"
31	HR193	Washer
32	HRH12125-8	Capscrew, 1/2" x 1 1/4" GR8
33	0-173	Lockwasher, 1/2"
34	HRSFW12	SAE Flatwasher, 1/2"

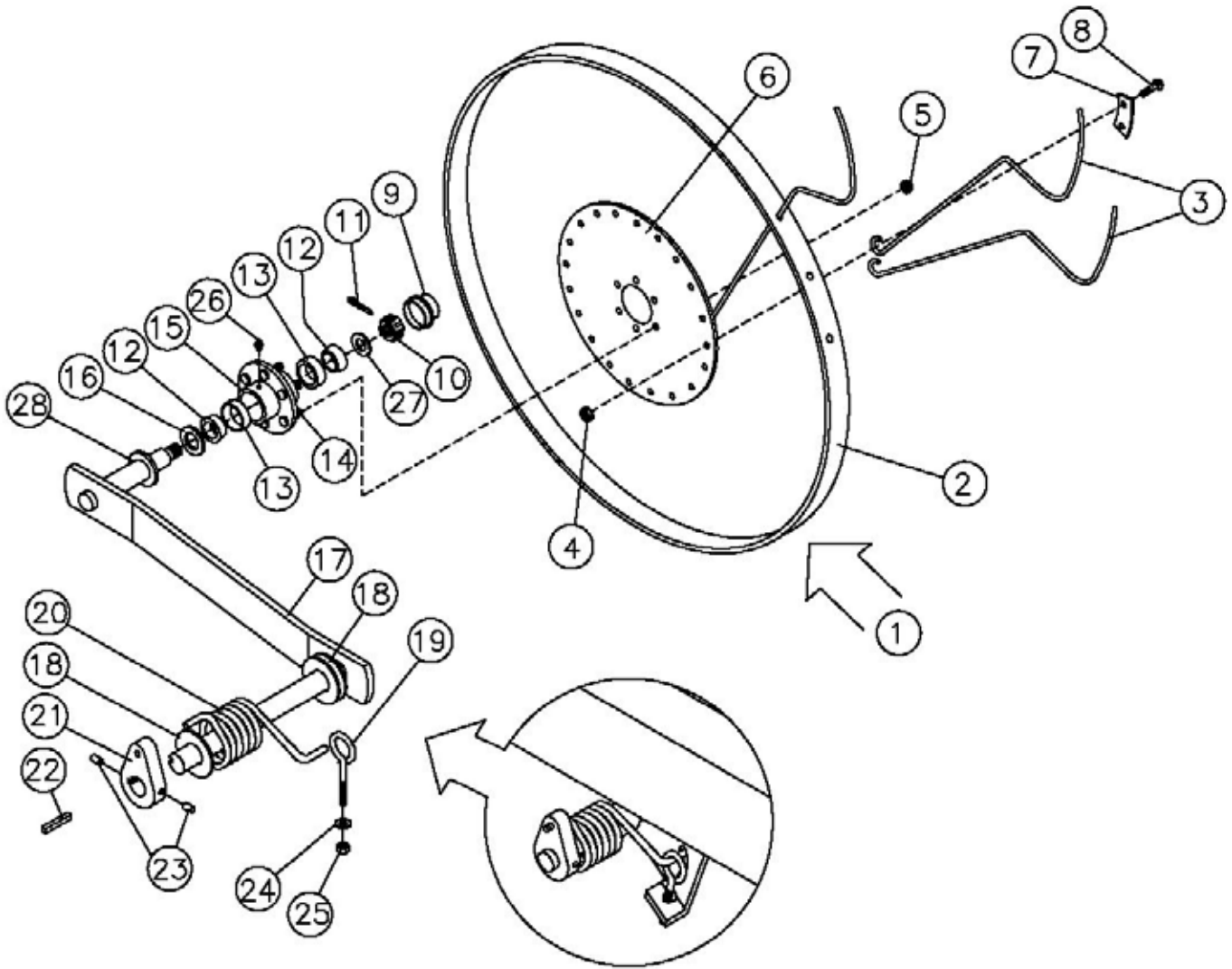

Rake Arm and Wheel Assembly

Item No.	Part No.	Description
1	HR118	Rake Wheel Complete, RH
	HR119	Rake Wheel Complete, LH
2	HR120	Rim
3	HR121	Tine, 7mm
4	HR122	Hex Nut, M10
5	HR123	Flange Nut, 3/8"
6	HR124	Flange
7	HR125	Tine Clamp
8	RP000369	Carriage Bolt, M10 x 25
9	909176	Hub Cap
10	953005	Hex Castle Nut, 1"-14
11	909454	Cotter Pin, .15" x 1.5"
12	910253	Bearing Cone, L44649
13	910250	Bearing Cup, L44610
14	3819	Stud, 3/8"
15	105026	Hub with cups
	105026C	Hub complete
16	906202	Seal
17	HR147	Rake Arm with welded in spindle
	HR150	Rake Arm with welded in spindle & hub
18	VM-719	Machine Washer, 1 1/4" 18 ga.
19	VM-609	Eye Bolt, 3/8" x 3"
20	VM-607	Torsion Spring, RH
	VM-608	Torsion Spring, LH
21	HR152	Spring Block
22	HR151	Key, 1/4" x 1/4" x 13/16"
	HR151-2	Woodruff Key, 1/4" x 3/4"
23	VM-718	Set Screw, 3/8" x 1/2"
24	MCH38F	Flatwasher, 3/8"
25	HRH380	Nylock Hex Nut, 3/8"
26	M61	Grease Zerk, M6
27	913576	Washer
28	N807-P	Seal Protector

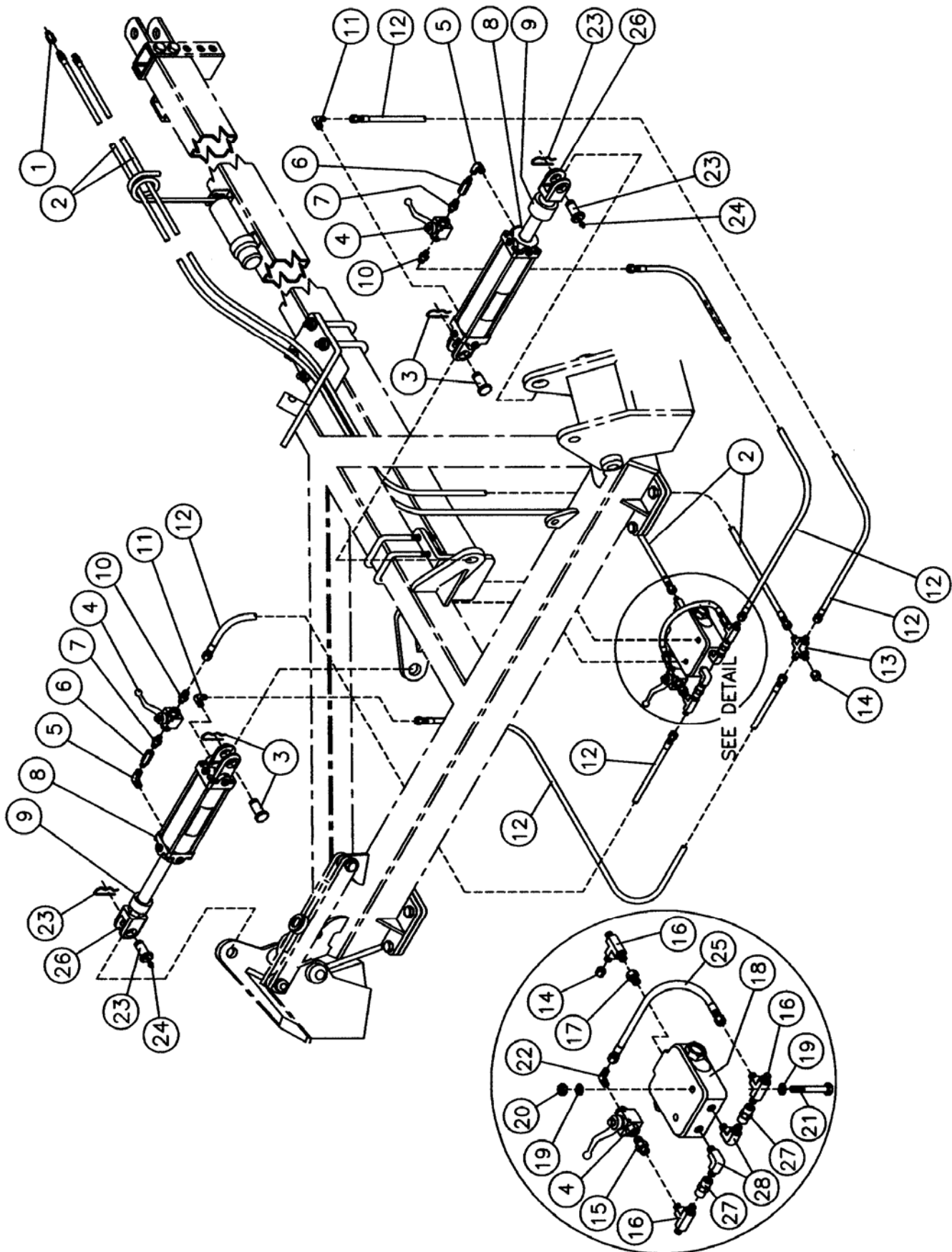

Hydraulic System Parts List

Item No.	Part No.	Description	Qty.
1	8010-4	Hydraulic Tip	2
2	HR145	Hydraulic Hose, 216"	2
3	HR128	Cylinder Pin and Clip	2
4	242-131	Hydraulic Shut Off Valve, ¼"	3
5	8MP-8FP90	Elbow, 90°	2
6	FR-50-062	Restrictor	2
7	4MP-8MP	Fitting, 4MP-8MP	2
8	HR173	Hydraulic Cylinder, 3 ½" x 8" ASAE	2
	HR197	Seal Kit, 3 ½" Cylinder 639577 Monarch	
	HR199	Seal Kit, 3 ½" Cylinder 46906 Grizzly	
9	HR138	Hydraulic Cylinder Stroke Adjuster	2
10	4MJ-4MP	Fitting, 4MJ-4MP	2
11	4MJ-8MP90	Elbow, 90°	2
12	HR172	Hydraulic Hose, 13" 4FJX-4FJX	4
13	4MJ-CROSS	4 Way Fitting, 4MJ	1
14	4FJ-CAP	Cap, 4FJ	2
15	4FJX-4MP	Fitting, 4FJX-4MP	1
16	4MJ-4MP-4MJ	Tee, 4MJ-4MP-4MJ	3
17	4FP-6MP	Fitting, 4FP-6MP	1
18	HR213	Flow Divider	1
19	FW14	Flatwasher, ¼"	4
20	HRH140	Nylock Nut, ¼"	2
21	HRH143	Capscrew, ¼" x 3"	2
22	4MJ-4MP90	Elbow, 90°	1
23	HR128Z	Cylinder Pin and Clip	2
24	VM-605-90	Grease Zerk, ¼" 90°	2
25	HR195	Hydraulic Hose, 13" 4FJX-4FJX (Gates)	1
26	HR196	Cylinder Clevis, Split 56892 Grizzly	
	HR198	Cyl. Clevis w/small set screw 492652 M	
27	4FP-4FP	Fitting, Coupler 4FP-4FP	2
28	6MP-4MP90	Elbow, 90°	2

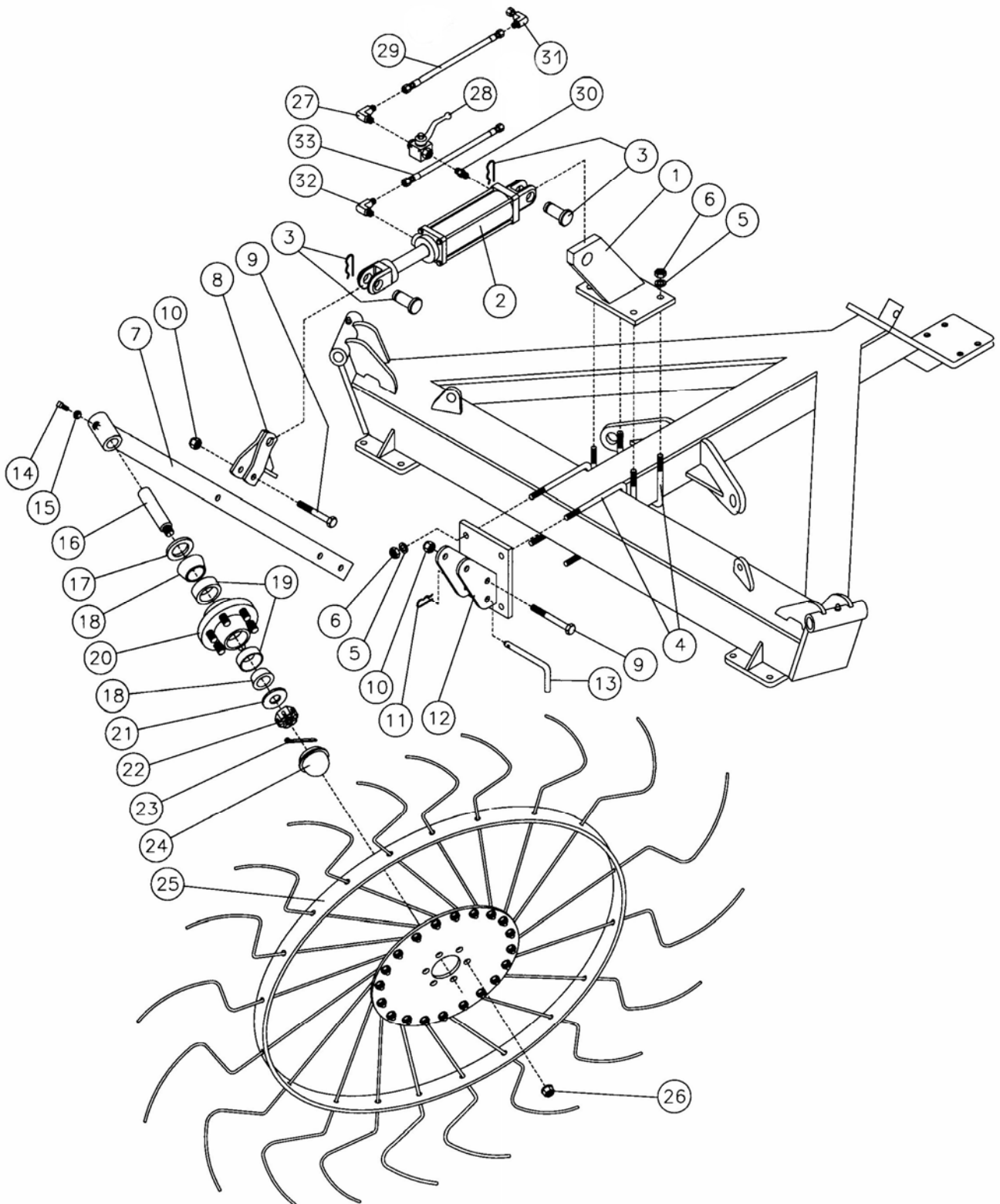

Single Wheel Center Wheel Kit

Item No.	Part No.	Description	Qty.
1	HR126	Mounting Bracket	1
2	HR127	Hydraulic Cylinder, 2" x 6"	1
	HR156	Seal Kit, 2" Cylinder 46900 Grizzly	
3	HR128	Cylinder Pin and Clip	2
4	UB587	U Bolt, 5/8" x 5 1/16" x 6 5/8"	4
5	OE-155	Lockwasher, 5/8"	8
6	OE-154	Hex Nut, 5/8"	8
7	HR129	Wheel Arm Weldment	1
8	HR130	Pivot Stop Weldment	1
9	HRH584	Hex Capscrew, 5/8" x 4"	2
10	HRH580	Nylock Nut, 5/8"	2
11	0-56	Hairpin Clip	1
12	HR131	Pivot Mounting Bracket	1
13	0-55	Pin	1
14	0-178	Square Head Set Screw, 1/2" x 1 1/4"	1
15	0-179	Jam Nut, 1/2"	1
16	105029L7.45	Spindle	1
	105024L7.75	Hub & Spindle complete, Rake	1
17	906124	Seal, CR12407	1
18	910253	Bearing Cone, L44649	2
19	910250	Bearing Cup, L44610	2
20	105027	Hub with cups	1
	105027C	Hub Complete	1
21	913576	Washer	1
22	953005	Castle Nut, 1"-14	1
23	905454	Cotter Pin	1
24	909176	Hub Cap	1
25	HR118	Rake Wheel, RH	1
26	HR123	Flange Nut, 3/8"	6
27	4MJ-4MP90	Elbow, 90°	1
	4MJ-6MP90	Elbow, 90°	1
28	242-131	Hydraulic Shut Off Valve, 1/4"	1
	242-132	Hydraulic Shut Off Valve, 3/8"	1
29	HR144	Hydraulic Hose, 24"	1
30	4MP-6MP	Fitting	1
	6MP-6MP	Fitting	1
31	4MJ-4FJX90	Elbow, 90°	1
32	4MJ-6MP90	Elbow, 90°	1
33	HR148	Hydraulic Hose, 36"	1

Single Wheel Center Wheel Kit Installation

CAUTION! Wear proper protective equipment such as safety glasses and protective shoes when assembling.



Use the following instructions to install a single wheel Center Wheel Kit on the *Hybrid* Hay Runner.

1. Layout and identify all parts. Refer to the parts diagram on page 22 and parts list on page 23 for assistance in identifying parts.
2. Lower the rakes to the ground and release the hydraulic pressure by working the tractor's hydraulic lever with the engine off.
3. Attach the Pivot Mounting Bracket to the Hay Runner frame using 5/8" U Bolts, Lockwashers and Hex Nuts. Be sure the Bracket is mounted with the ears facing upwards as shown in the picture below.

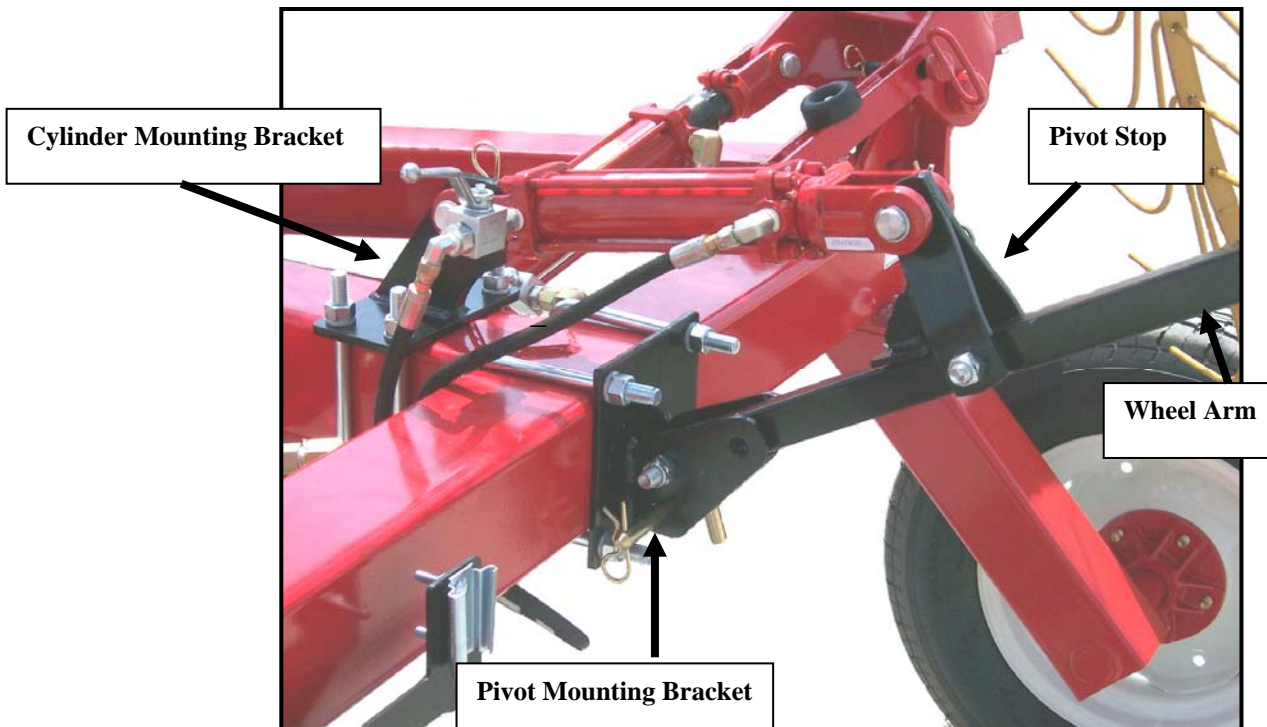

4. Attach the Cylinder Mounting Bracket, with the ear facing rearward, on top of the Hay Runner Frame, as shown, using 5/8" U Bolts, Lockwashers and Hex Nuts.

5. Attach the Pivot Stop Weldment to the Wheel Arm Weldment using a 5/8" Hex Capscrew and Nylock Hex Nut. Do not completely tighten the Nylock Nut. The Pivot Stop Weldment must be able to pivot.
6. Attach the Wheel Arm Weldment to the Pivot Mounting Bracket using a 5/8" Hex Capscrew and Nylock Nut. **Note:** Attach the Wheel Arm to accommodate a right Hand Rake Wheel.
7. Insert the Hub and Spindle Assembly into the Wheel Arm Weldment and secure in place using the Square Head Set Screw and Jam Nut.
8. **Note:** Do not use Teflon thread tape. Only use a liquid type thread sealant. Install a 90° 4MJ-6MP Elbow in the ram end port of the 2" x 6" Hydraulic Cylinder. Install a 4MP-6MP in the other port of the Hydraulic Cylinder. Attach the Hydraulic Shut Off Valve to this fitting and then install a 90° 4MJ-4MP elbow in the Hydraulic Shut Off Valve.
9. Install the Hydraulic Cylinder on the Mounting Bracket and attach to the Pivot Stop Weldment using the Cylinder Pins and Clips. Be sure the ram end is attached to the Pivot Stop.
10. Make sure the hydraulic pressure has been released. Locate and remove the Cap on the Tee at the front side of the Flow Divider and install the 36" Hydraulic Hose between the Tee and the Ram end of the Hydraulic Cylinder.



11. Locate and remove the cap on the 4 Way Fitting that connects the other Hydraulic Hose from the tractor and the lines from the Shut Off Valves on the 3" x 8" Wing Hydraulic Cylinders. Connect the Hydraulic Hose from the Shut Off Valve on the 2" x 6" Center Wheel Kit Cylinder, using the 24" Hydraulic Hose, to the 4 Way Fitting.

12. Mount the RH Rake Wheel on the Hub and secure with the Flange Nuts supplied.

13. Start the tractor and check for hydraulic leaks. With the Center Wheel Transport Lock Pin removed and the Center Wheel Shut Off Valve and Wing Shut Off Valves in the open position operate the hydraulics raising and lowering the Rakes and Center Wheel in order to remove any air trapped in the system. It may take several cycles to remove all of the air. The Center Wheel should raise and lower in conjunction with the Rakes if properly installed.

CAUTION!



Always wear protective eye goggles and use a magnifying glass or hold a piece of wood on suspected leaks. Pinhole hydraulic leaks can penetrate skin. Do not touch.

CAUTION!



Make sure the area around the machine is clear before lowering. Do not lower machine when people or pets are near the machine or folding mechanism.

Notes:

2 Wheel Center Wheel Kit (V design)

Item No.	Part No.	Description
1	HR177	Mounting Bracket
2	HR127	Hydraulic Cylinder, 2" x 6"
	HR156	Seal Kit, 2" Cylinder 46900 Grizzly
3	HR128	Cylinder Pin and Clip
4	UB587	U Bolt, 5/8" x 5 1/16" x 6 5/8"
5	OE-155	Lockwasher, 5/8"
6	OE-154	Hex Nut, 5/8"
7	HR178	Arm
8	HR179	Pivot Stop Weldment
9	HRH5845	Hex Capscrew 5/8" x 4 1/2"
10	HRH580	Nylock Nut, 5/8"
11	0-56	Hairpin Clip
12	0-55	Pin
13	HRH181	Hex Capscrew, 3/8" x 1"
14	K-308	Lockwasher, 3/8"
15	HR185	Stop Washer
16	4MP-6MP90	90° Elbow
17	242-131	Hydraulic Shut Off Valve, 1/4"
18	4MP-4MJ	Straight Fitting
19	HR182	Hydraulic Hose, 48"
20	HR148	Hydraulic Hose, 36"
21	4MJ-4FJX90	90° Elbow
22	4MJ-6MP90	90° Elbow
23	HR183	Adjustable Arm
24	HR123	Flange Nut, 3/8"
25	HRH38125	Capscrew, 3/8" x 1 1/4"
26	HR191	Spindle Arm, V
27	906124	Seal, CR12407
28	910253	Bearing Cone, L44649
29	910250	Bearing Cup, L44610
30	105027	Hub with cups
31	913576	Washer
32	953005	Castle Nut, 1"-14
33	905454	Cotter Pin
34	909176	Hub Cap
35	HR174	RH Rake Wheel, Small
	HR175	LH Rake Wheel, Small
36	HR186	Small Wheel Tine, 7mm
37	HR125	Tine Clamp
38	RP000369	Carriage Bolt, M10 x 25
39	HR122	Hex Nut, M10
40	HRH584	Hex Capscrew, 5/8" x 4"
41	HRH58SF	Flatwasher, 5/8" SAE

2 Wheel Center Wheel Kit Installation

CAUTION! Wear proper protective equipment such as safety glasses and protective shoes when assembling.



Use the following instructions to install the 2 Wheel Center Wheel Kit on the *Hybrid* Hay Runner. Refer to the parts drawing on page 28 and or page 30 for additional assistance.

1. Lower the rakes to the ground and release the hydraulic pressure by working the tractor's hydraulic lever with the engine off.
2. Attach the Cylinder and Lift Arm Mount to the Hay Runner frame using 5/8" U Bolts, Lockwashers and Hex Nuts. Attach the Lift Arm to the Cylinder and Lift Arm Mount using a 5/8" Capscrew and Nylock Nut. Install the Transport Lock Pin and Hairpin.



3. Attach the Pivot Stop Weldment to the Lift Arm using a 5/8" Hex Capscrew and Nylock Hex Nut. Do not completely tighten the Nylock Nut. The Pivot Stop Weldment must be able to pivot.

4. Slide the Rake Arm Weldment over the Lift Arm, as shown, and install the Stop Washer, Lockwasher and Capscrew. The Rake Arm Weldment has 3 possible positions and the preferred position is as close to the Hay Runner Frame as possible. The Rake Arm is held in position with a 5/8" hexhead capscrew, flatwasher and nylock nut. The picture below is incorrect as it is showing a pin and r clip.



6. Attach the Hub and Spindle Weldment to the Rake Arm using 4 capscrews and Whiz Nuts. Install the Rake Wheels. *Disregard* decals RH or LH on the wheels and install them with the tines at the bottom of the wheels pointing forward and the carriage bolt heads on the center flange towards the hay.



7. **Note:** Do not use Teflon thread tape. Only use a liquid type thread sealant. Install a 4MJ-6MP 90° Elbow in the lower port of the 2" x 6" Hydraulic Cylinder and then attach the 36" Hose. The Shut Off Valve will be mounted parallel with the Cylinder with the Handle pointing away from the Cylinder and free to rotate. Refer to drawing on page 28 or page 30. With the Valve Handle pointing towards you install a 4MP-6MJ straight fitting in the LH side of the Shut Off Valve and a 4MP-6MP 90° Elbow in the other side. Attach this assembly, using the Elbow, to the ram port of the cylinder then attach the 48" hose.

8. Install the Hydraulic Cylinder on the Mounting Bracket and attach to the Pivot Stop Weldment using the Cylinder Pins and Clips. Be sure the ram end is attached to the Pivot Stop as shown in the picture.



9. Make sure the hydraulic pressure has been released. Locate and remove the Cap on the Tee at the front side of the Flow Divider and install the 48” Hydraulic Hose coming from the Ram end port of the Hydraulic Cylinder. Locate and remove the cap on the 4 Way Fitting that connects the other Hydraulic Hose from the tractor and the lines from the Shut Off Valves on the 3” x 8” Wing Hydraulic Cylinders. Install a 4MJ-4FJX 90° Elbow and connect the 36” Hydraulic Hose coming from the lower port on the 2” x 6” Center Wheel Kit Cylinders.

10. Start the tractor and check for hydraulic leaks. With the Center Wheel Transport Lock Pin removed and the Center Wheel Shut Off Valve and Wing Shut Off Valves in the open position operate the hydraulics raising and lowering the Rakes and Center Wheel in order to remove any air trapped in the system. It may take several cycles to remove all of the air. The Center Wheel should raise and lower in conjunction with the Rakes if properly installed.

CAUTION!



Always wear protective eye goggles and use a magnifying glass or hold a piece of wood on suspected leaks. Pinhole hydraulic leaks can penetrate skin. Do not touch.

CAUTION!



Make sure the area around the machine is clear before lowering. Do not lower machine when people or pets are near the machine or folding mechanism.





Hybrid Hay Runner Warranty Policy

Ogden Metalworks, Inc. warrants this product to be free from defects in material and/or workmanship under normal use and service for one year from the date of delivery by the dealer to the original purchaser. This warranty is only applicable if the unit is set up and operated as intended under normal service and in accordance with the instruction manual. Ogden Metalworks, Inc.'s obligation under this warranty is limited to the replacement of any part or parts which are determined defective by Ogden Metalworks, Inc. due to factory workmanship and/or material. Parts or components, if requested by Ogden Metalworks, Inc., must be returned through the selling dealer or distributor directly to Ogden Metalworks, Inc. with all transportation charges prepaid, for inspection and determination of warranty. This warranty does not cover common wear items or component parts not manufactured by Ogden Metalworks except to the extent of their manufacturer's warranties. This warranty does not cover, under any circumstances, any parts, components, or materials which have been subjected to neglect, misuse, alteration, accident or if repaired with parts other than those manufactured by and obtained from Ogden Metalworks. Credit for required labor will be issued at the company's discretion.

This warranty is extended solely to the original purchaser and is not transferable. This warranty is not valid unless the warranty card has been returned to Ogden Metalworks, Inc. within 30 days from the date of purchase by the end user.

Ogden Metalworks, Inc.

Ogden Metalworks, Inc. reserves the right to change specifications and dimensions without notice.

Warranty will not be valid unless card is returned

Hybrid Hay Runner Warranty Card

Please print Purchased Date _____

Name _____

Address _____

Address _____

Serial Number _____ Model _____

Dealer _____

Address _____

